

Wrapping machine

- *Totally automatic*
- *It can be started up, even whilst remaining on the lift truck*

Mod. AV160 Auto



CE

*automatic
and economical*

Motorised film pre-stretching device

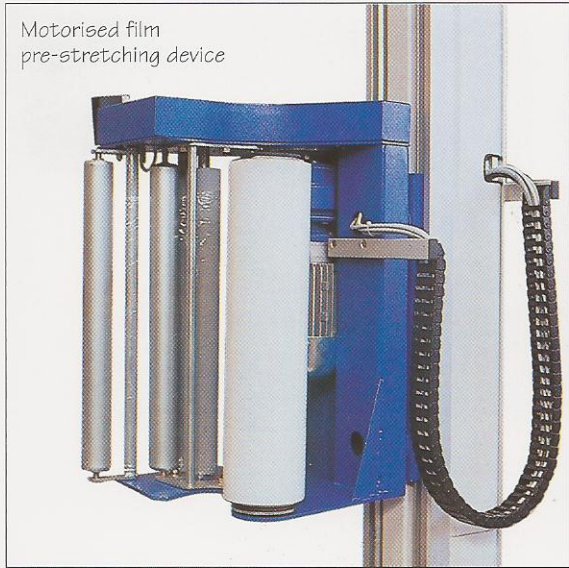

Wrapping machine

OMS
OFFICINA MECCANICA SESTESE S.p.A.

Designed for medium scale productions, model **AV160 Auto** is a **low cost** wrapping machine, for the automation of line-ends. Its features: complete with a totally automatic film stapling, cutting and welding device. It uses stretching film or plastic mesh.

The **AV160 Auto** wrapping machine may be powered by the lift truck in which case the starting of the wrapping cycle may be activated by the operator using a remote control from his driver's seat on the lift truck.

As well as the pulpit on which the main machine button panel is positioned, a secondary button panel is supplied to begin the cycle start operation, to be positioned in the vicinity of the pack loading/unloading zone.

A luminous column, placed on the protective netting, indicates automatic operation mode, it only goes off at the end of the cycle or in the event of an emergency.

Features

- low wrap regulation counter;
- high wrap regulation counter;
- film stretch regulator;
- adjustable film overlay;
- an infra-red detector engages the alarm and automatically stops the machine in the event that the light beam is interrupted by any kind of tampering.

Optionals

- pneumatic pressure device for unstable packs;
- remote control for starting the wrapping cycle;
- sealing device;
- Motorised film pre-stretching device;
- with an automatic top-sheet dispenser.



The OMS wrapping trade mark

Standard model dimensions

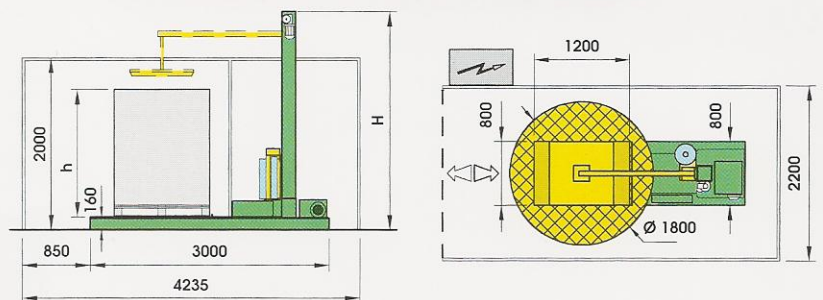

Version with pneumatic pressure element

Column H 2750 mm, pack minimum h 700 mm, maximum h 1700 mm
 Column H 3050 mm, pack minimum h 800 mm, maximum h 2000 mm
 Column H 3450 mm, pack minimum h 1100 mm, maximum h 2300 mm

Technical data

- Turn table height: 160 mm;
- table diameter: 1800 mm;
- acceptable pallet size: 800 x 1200 mm* and 1000 x 1200 mm*;
- max. pallet height: 2200 mm* (without pressure device)
1650 mm* (with pressure device);
- max. pallet weight: 1700 kg;
- production rate: 30 ÷ 40 pallets per hr. according to the wrapping cycle;
- film thickness: 17 ÷ 35 µm;
- film width: 500 mm*;
- film reel diameter: max. external Ø 300 mm, internal Ø 76 mm;
- electrical power value: 230/400 V, 50 Hz;
- installed electric power: 2 kW;
- compressed air supply: 1/4", 6 bar.

The values marked with * indicate a standard version.



Automatic top-sheet dispenser

